

HPR2-150IR105/HPR2-150IR120  
 HPR2-150IR130/HPR2-150IR145  
 HPR2-150IR155/HPR2-150IR165

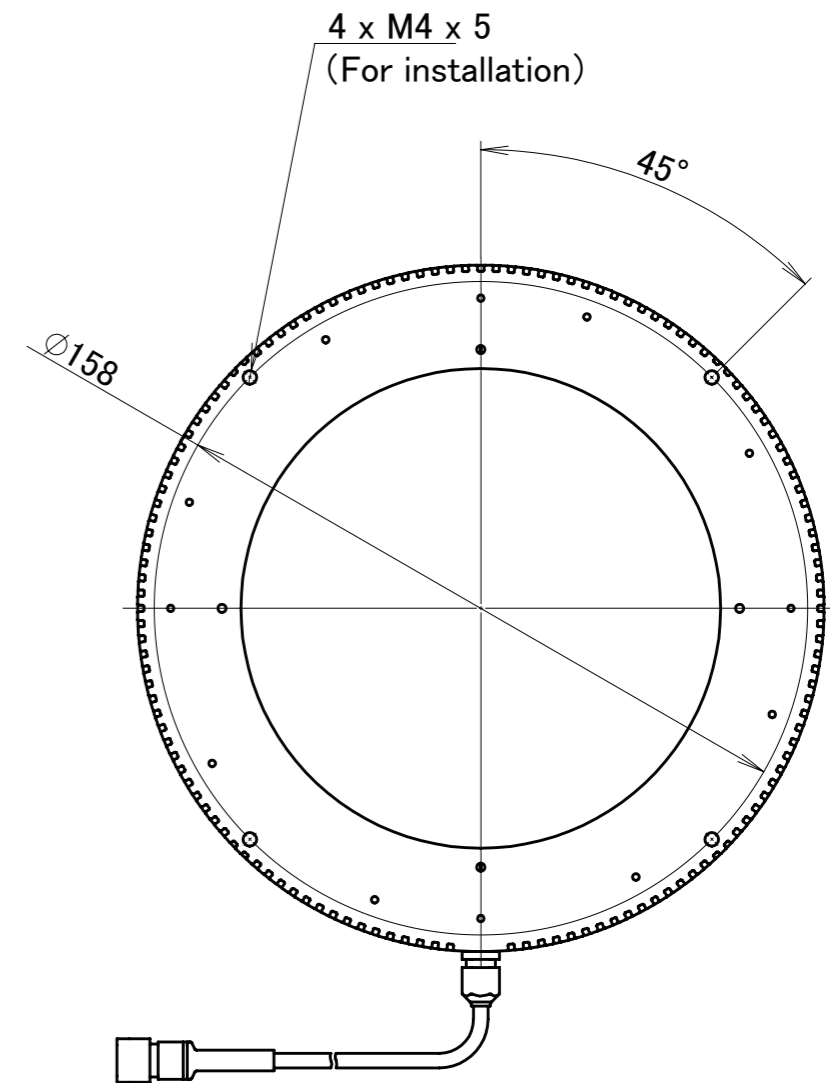
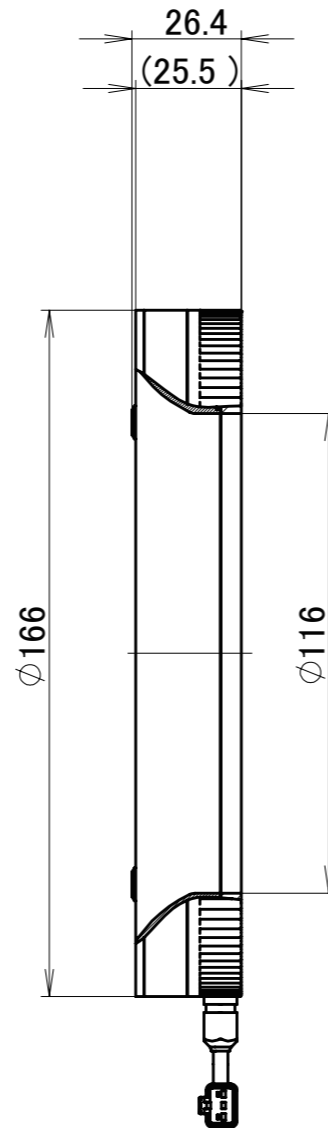
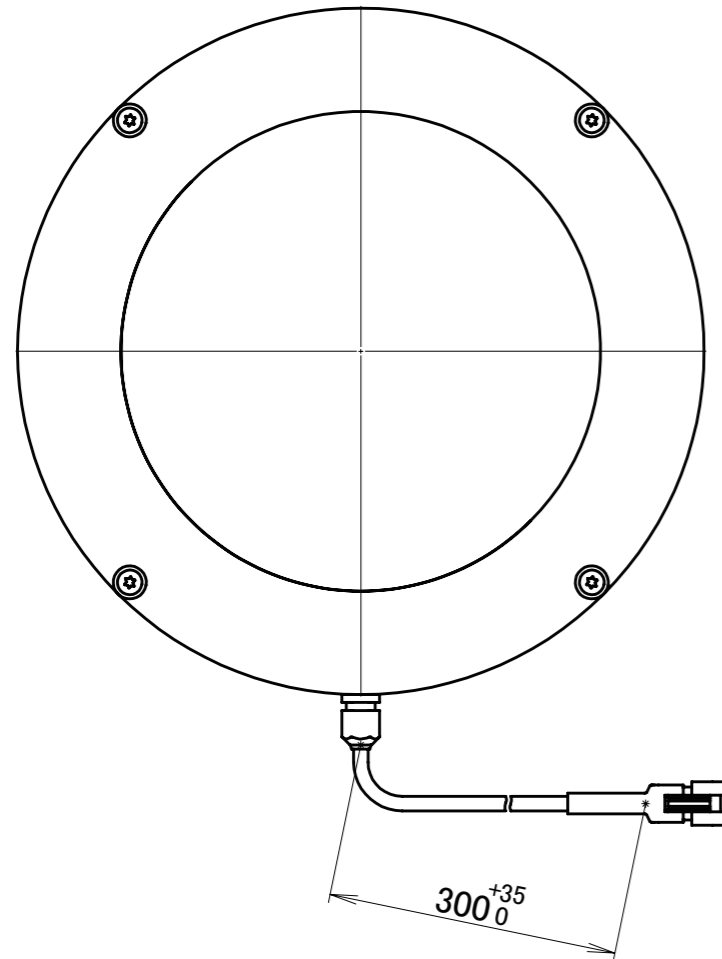

Model	Power consumption
HPR2-150IR105	19W max.
HPR2-150IR120	16W max.
HPR2-150IR130	15W max.
HPR2-150IR145	13W max.
HPR2-150IR155	13W max.
HPR2-150IR165	13W max.

Input Voltage: DC 24V

Power Consumption: Table reference

Mass: 0.25kg(Approx.)